

Type 10 Activity Vehicle Driver Manual

2005

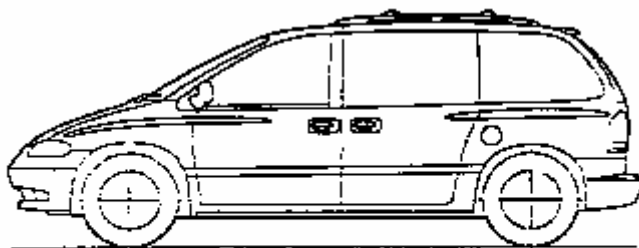

Mini Van or Car

**OREGON DEPARTMENT OF EDUCATION
PUPIL TRANSPORTATION**

INTRODUCTION

This Activity Driver Handbook is designed to give the basic information needed for Type 10 Activity Drivers. Districts may want to add additional information to this document that is specific to your local area. This could be items such as, fueling, breakdown procedures and the paperwork necessary to reserve the vehicle. The content of this manual includes aspects of driving which could differ from driving a vehicle for personal use. All or any part of this document may be photocopied for educational purposes without permission from the Oregon Department of Education.

Minimum requirements for Type 10 vehicles and drivers are:

- | | |
|------------------------------|---|
| Vehicle | <ul style="list-style-type: none">• 10 passengers or less including the driver• 10,000 pounds or less |
| Driver | <ul style="list-style-type: none">• 18 years old• Possess first aid card• Pass driving and criminal records check• Be judged by an authorized official as having ability to operate the Type 10• Be on an approved driver list maintained at the Oregon Department of Education |
| Training Requirements | <ul style="list-style-type: none">• Emergency procedures and evacuation training• Pretrip training• Specialized training for special education transportation |

;

FOREWARD

The goal of every activity trip is to have a safe and enjoyable trip. In 1985, the Oregon Legislature looked at the issue of student transportation. Their findings reflected a weakness in the safety standards and training of drivers who transported students on school activity trips in non-school bus vehicles. The 1985 Legislature passed Senate Bill 326, which required the Oregon Department of Education to adopt standards to control all publicly owned non-school bus vehicles.

In December 1985, the Oregon Department of Education began the task of establishing those standards. They held a series of hearings throughout the state involving transportation directors, supervisors, school bus contractors, and school administrators from public and private schools. Their goal was to establish standards that could be implemented with the needs of the individual school in mind.

This manual has been prepared to provide activity vehicle drivers and school officials with pertinent material relating to safe and efficient school transportation. It is not intended to take the place of motor vehicle laws, school laws and rules, or a first aid manual. Rather, it is a resource for answering the day-to-day questions that arise in connection with activity vehicle driver's responsibilities. Every driver should be thoroughly acquainted with the contents of this publication and a copy should be kept available as a reference source.

Oregon motor vehicle laws are passed by the Oregon Legislature and identified by an Oregon Revised Statute (ORS) number. Pupil transportation regulations are adopted by the State Board of Education and are identified by an Oregon Administrative Rule (OAR) number.

TABLE OF CONTENTS

	Page
Type 10 Program	6
LIABILITIES, RULES AND ADVISORY MATERIAL	7
IN LOCO PARENTIS.....	7
NEGLIGENCE.....	7
CONTRIBUTORY NEGLIGENCE	7
PARENTAL REQUESTS.....	8
DRIVING IN ADVERSE WEATHER CONDITIONS	8
RAIN.....	8
FOG AND SMOKE	9
SNOW AND ICE.....	10
STEERING TO GET OUT OF A SKID	12
WINDSTORM AND EARTHQUAKE.....	13
EMERGENCIES	14
DISABLED VEHICLE	14
WARNING REQUIREMENTS	14
PLACEMENT OF WARNING DEVICES (Reflective Triangles).....	14
FIRST AID.....	16
“GOOD SAMARITAN” LAW	17
EVACUATION DECISION.....	17
EMERGENCY EXITS.....	18
EVACUATION PROCEDURES.....	18
ACCIDENT REPORTING PROCEDURES.....	20
MISCELLANEOUS REGULATIONS.....	21
DRIVING HOURS	21
SPEED LAWS	21
SEAT BELTS AND SAFETY SYSTEMS	22
CELL PHONES	22
CARGO	22
FUELING.....	22
APPENDIX A	24
OREGON ADMINISTRATIVE RULES	24
OAR 581-053-0006(8) Driving and Criminal Records:	24
OAR 581-53-015(7) Accident reporting requirement	25
OAR 581-053-0545 Type 10 Pupil Transporting Vehicle standards and rules for operation	25
OAR 581-053-0550 Type 20 Pupil Transporting Vehicle Standards	31
APPENDIX B	36
OREGON REVISED STATUTES.....	36
ORS 30.800 Liability for emergency medical assistance by medically trained persons.	36
ORS 30.805 Liability for emergency medical assistance by government personnel.	36
ORS 811.111 Violating a speed limit; penalty.	37
ORS 811.210 Failure to use safety belts; penalty.	37

ORS 811.225 Failure to maintain safety belts in working order; penalty.	38
811.460 Failure to follow rail crossing procedures for high-risk vehicles; application; penalty.....	38
ORS 811.455 Failure to stop for railroad signal; penalty.	39
ORS 811.465 Exemptions from high-risk vehicle rail crossing procedures.	40
ORS 811.530 Failure to post warnings for disabled vehicle; application; penalty.....	40
ORS 820.190 Minor operating school vehicle; penalty.	41
APPENDIX C	42
FORMS.....	42

Type 10 Program

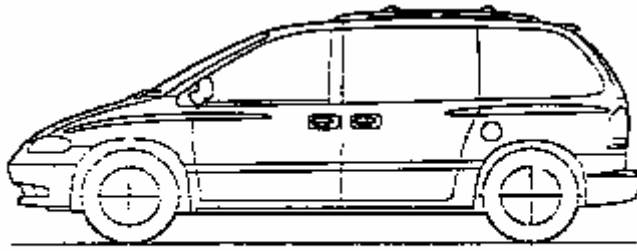

Mini Van or Car

Type 10 vehicles shall have a designed capacity of not more than 10 persons including the driver, shall have a gross vehicle weight rating of not more than 10,000 pounds and are used to transport students to and from school or authorized school activities. A 12 or 15 passenger vehicle that has been reduced does not qualify as a type 10 vehicle.

An annual inspection shall be completed for this vehicle (all applicable items on Form 581-2255), and certification of inspection and repair (Form 581-2256) shall be returned to ODE by September 1 of each year.

The drivers of this vehicle must meet the requirements of a school activity vehicle driver. They must possess a valid driver license or commercial driver license, and be at least 18 years of age. They must be placed on an approved driver list maintained at the Oregon Department of Education by filing **Form 581-2279**.

The vehicle may be almost any passenger carrying vehicle that complies with federal construction standards. Some examples include: station wagon, suburban, mini van, pickup, sedan.

LIABILITIES, RULES AND ADVISORY MATERIAL

IN LOCO PARENTIS

The school district is a creation of the State. Oregon's Attorney General has ruled that the District is to act "in loco-parentis" – in place of the parent – giving all public school students reasonable care while they are under the supervision of school personnel during transportation, and at school. Although no "unreasonable effort" is required, it is plain that all school employees are duty-bound to protect school children and report anything that is detrimental to the children's safety or welfare.

NEGLIGENCE

If a civil suit is filed against an activity vehicle driver, the plaintiff must prove that the driver was negligent or failed to take reasonable action to avoid the accident. A defendant who can demonstrate that he/she followed applicable laws and regulations, acted in a prudent manner and exercised good judgment, will most likely win the case.

It is, therefore, important for you to understand all school district policies and drive defensively, following all motor vehicle speed laws. Using a school vehicle for unauthorized activities, carrying unauthorized passengers, violating a law or regulation, or ignoring obvious hazards can be used against the accused as evidence of negligence.

On rare occasions, it may be necessary to put policy aside for the sake of prudence. As an example, if school policy dictates that no school personnel shall touch any student, but you grabbed a student who was about to step off the vehicle into a car which was illegally passing on the right and was approaching the open door. If you did not have time to close the door or caution the student, no one could dispute that you acted in a prudent manner. But if you knowingly violate policy, there must be a very good reason for it. There is no excuse for unknowingly violating a policy or traffic law.

CONTRIBUTORY NEGLIGENCE

Gone are the days when a defendant could be spared from liability by showing that the claimant contributed to an accident. Under the new insurance law, the defendant can be held responsible for a portion of the damages, even if the plaintiff shares responsibility for the accident.

The new comparative negligence law permits the damages to be divided according to the percentage of each party's negligence, as determined by the court.

PARENTAL REQUESTS

It is impossible to overemphasize the importance of following District policy and letting pupils off the vehicle only at their assigned destination and schools. Let no one persuade you to do otherwise. Most District policies require that the parent give written permission in advance for any deviation from this schedule. You should keep the notes from parents until you are sure there will be no repercussions.

If a parent asks you to do anything that you consider unsafe or that violates school policy, clear the request with your supervisor or school officials before you make any effort to comply, even if the request is in writing. A parent cannot sign away the rights of the child to reasonable protection.

DRIVING IN ADVERSE WEATHER CONDITIONS

Bad weather does not cause accidents, but it certainly adds more danger to driving and makes normal hazards worse. Drivers who do not adjust their driving to meet weather conditions cause accidents.

RAIN

In much of Oregon, rain is normal hazard, at least during the school year. Rain poses several problems.

You can expect slipperiness, especially after a long dry spell or at the beginning of a rain, before the oil, soil, and other materials have been washed away. The center of the road remains soiled longer than the edges. Allow more time than usual to stop the vehicle and keep in mind that when braking you will cover more distance than on dry pavement.

Your vision is reduced and so is everybody else's. A misty rain can make the windshield blurry, unless it is very clean.

Precautions include:

1. Reduce speed.
2. Use windshield wipers.
3. Drive well to the right.
4. Make turns slowly, using the brake as little as possible.
5. Use headlights (a good practice at any time).

Often it is raining when the activity trip starts. Go out to prepare your vehicle early enough to clean the windows, lights, and mirrors carefully. Check the wipers and start out ahead of the usual time to help compensate for the reduced driving speed.

When you must drive through water several inches deep, the brakes usually become wet. Upon emerging, test the brakes and, if necessary, apply light pressure to the pedal while driving slowly to let the heat generated by the brakes dry the linings. Do not resume normal speed until the brakes function properly.

Travel very slowly through deep water to avoid splashing water into the motor, which may cause it to stall.

Detour or call for instruction rather than proceed into water of unknown depth or where the roadbed may have washed out.

FOG AND SMOKE

The primary concern when driving through fog and smoke is poor visibility. The safest rule for driving in fog is "DON'T". Realistically though, you have to be able to maneuver the vehicle in spite of the weather.

There are some things you can do to be as safe as possible, such as:

1. Use the windshield wipers and defroster continuously.
2. Drive with low beam headlights, which throw the light down the road where you need it. High beams only put the light into the fog to be reflected back to you. (Again, it is best to use headlights at all times.)
3. Signal stops by tapping the brake pedal to make the stoplights blink. Use hazard lights. Rear-end collisions are especially apt to occur in a fog while a driver is stopping or starting up after a stop.
4. Drive as far to the right of the center line as possible while you watch the road edge so that you will not run off the road and hit culvert heads, pedestrians, or parked vehicles.
5. Assume that you might have to make an emergency stop within the distance you can see ahead, no matter how short it is. If this means crawling, crawl!
6. When fog lies in patches, enter the patches at a greatly reduced speed. Never slow down suddenly in a fog.

Especially in western Oregon, during the summer and autumn months, smoke from field burning often presents much the same hazards as fog.

SNOW AND ICE

Do not blame the weather report for an accident. You and your vehicle must be prepared to face the situation. Make certain that:

1. You go to your vehicle early so that you can make thorough preparations and start your trip earlier than usual.
2. Chains are secure. (Call Transportation if you need help with your chains.)
3. Lights, mirrors, and front and rear windows are clear.
4. All exits operate smoothly.
5. Vehicle is well warmed up.
6. Heater and window defroster are working.

STARTING—

Before you start the vehicle on slippery surface, take two or three deep breaths as you repeat in you mind, “Slow and steady, slow and steady.”

On glare ice, chains increase starting ability by some seven times. Studs increase your starting ability several times, perhaps half as much as chains. Snow tires are of no help.

On snow, chains increase your starting ability as well as they do on ice. Snow tires are about half as effective as chains. Studded snow tires are more helpful than plain snow tires, but less helpful than chains.

To avoid spinning the wheels, feed less power to the drive shaft than you do on a dry day. Accelerate slowly and steadily. As you pull out onto the road, allow for ample stopping time and maintain greater distance than usual from other vehicles.

ON THE ROAD—

Of course, you usually see snow and ice, but beware of “black ice”, which often looks like ordinary wet pavement. On any snow or ice, judge the effect of traffic and the temperature on surface friction. When ice is melting, look far ahead, watching for spots where direct sunlight may have melted the ice quickly and for shaded areas. Overpasses and tunnels will stay icier longer than the rest of the road.

Drive at speeds below those posted, especially on hills, curves, and bridges, as well as in tunnels. Approach all curves slowly and make smooth turns so that you do not have to brake. Select the correct gear for the adjusted rate of speed and brake as little as possible.

The key to control of any vehicle is to avoid locking or spinning the wheels, so try to brake occasionally as you get the feel of the road. Experts do not skid! When you approach intersections and stops, pump the brakes once or twice.

If snow, ice, or steam builds up on the front or rear window, stop the vehicle and brush it off. Follow at a safe distance. That way you will not have to try to explain why the other person was able to stop and you were not.

STOPPING—

Temperature changes alter traction and braking distances greatly. As temperature rises, ice and snow become much more slippery. If at zero degrees you need just 120 feet to stop a school vehicle from a given speed, at 30 degrees you need 225 feet to stop a vehicle traveling at the same speed!

When you have good chains or tires, it is easy to think your stopping power is better than it really is.

On glare ice, chains cut stopping distance almost by half, but this is nothing compared with the added starting power chains provide. Studs, which increase starting power by more than three (3) times, decrease the stopping distance by only one-third. Snow tires make no appreciable difference in stopping distance.

On loosely packed snow, chains cut the stopping distance by only one-third. Snow tires cut the stopping distance by about 20 percent, or one-fifth. Studs help very little when stopping in snow.

STEERING TO GET OUT OF A SKID

1.

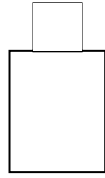

The vehicle is going straight.

2.

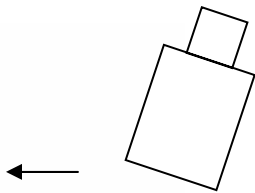

The back end of the vehicle skids to the left. The vehicle is now moving forward on an angle. Do not brake. Do not accelerate. Maintain power to the rear wheels.

3.

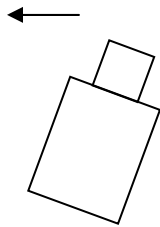

Steer left in the direction you want the vehicle to go.

4.

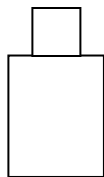

The vehicle is back on course.

5.

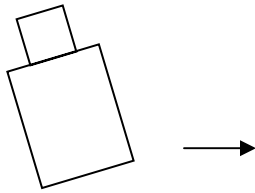

The back end fishtails to the right.

6.

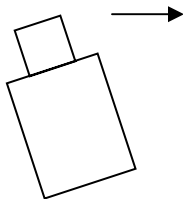

To control fishtailing in the opposite direction, counter steer right to get back on course. Repeat sequence as needed.

7.

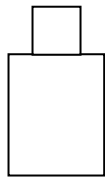

Steering control is reestablished. Carefully reduce speed to prevent recurrence.

WINDSTORM AND EARTHQUAKE

The major danger during windstorms or earthquakes are falling and flying objects.

In high wind, simply proceed with caution. Remember that the sides of the vehicle give a large area of exposure to the wind. Entering areas of cuts or fills exposes the vehicle to rapid changes in wind velocity.

Under severe conditions, if you are driving in an open area, pull over to the side of the road and stop. Otherwise, continue on the route until you come to a place where there are no buildings, trees, or overhead power lines.

Ask the students in the aisle seats to sit in the aisle and let the others move in away from the windows. If power lines are down, keep everyone in the vehicle and wait for help. Do not try jumping from the vehicle, as downed power lines often charge the ground around them.

After the apparent danger has passed, check to see that no power lines or debris present a hazard. If it is safe, proceed.

EMERGENCIES

In a true emergency, training alone will not assure safe and orderly behavior on the part of students, no matter how obedient they are and how well they have been taught.

Regardless of the mildness or severity of any emergency, the driver will have to take charge of students who are excited and, sometimes, panicked. If life or property were threatened or damaged because you lost control of the situation or lacked the knowledge to make the best decisions, you would not only have to live with the agony of regret – you might be held legally liable.

DISABLED VEHICLE

In spite of all we may do to provide for a safe and uneventful trip; circumstances may change that. The following will help you to be prepared for unplanned vehicle failure, accident, and/or student problems, which require you to stop and take action.

WARNING REQUIREMENTS

If you must stop on a road or the shoulder of any road, you must put out your emergency warning devices within 10 minutes as required by ORS 811.530. Placement of the reflectors will vary depending on the circumstances and the terrain.

The following pages illustrate placement of reflectors in various situations:

PLACEMENT OF WARNING DEVICES (Reflective Triangles)

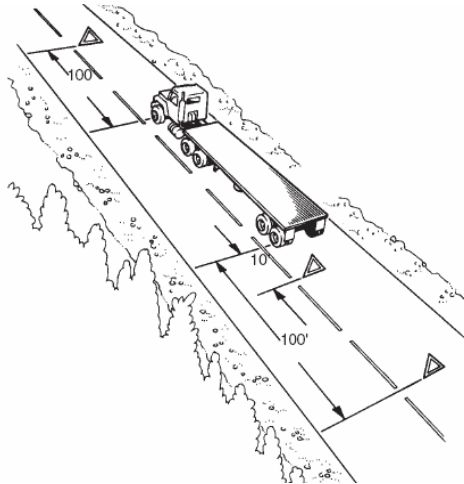

**Warning Device Placement:
Two Lane (traffic in both directions) or Undivided Highway**

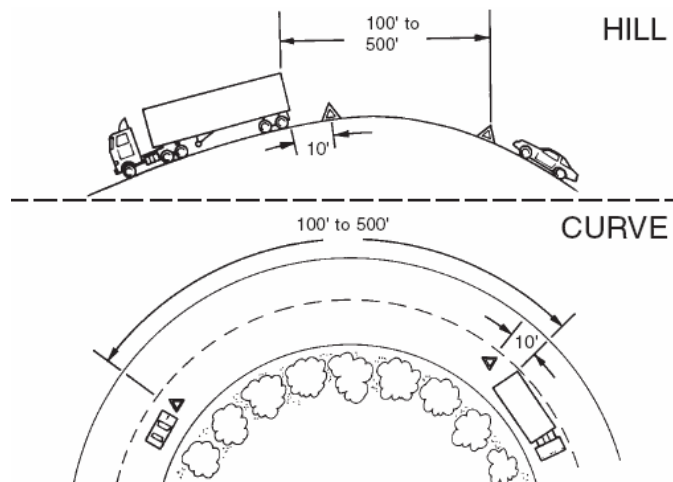

**Warning Device Placement:
Obstructed View**

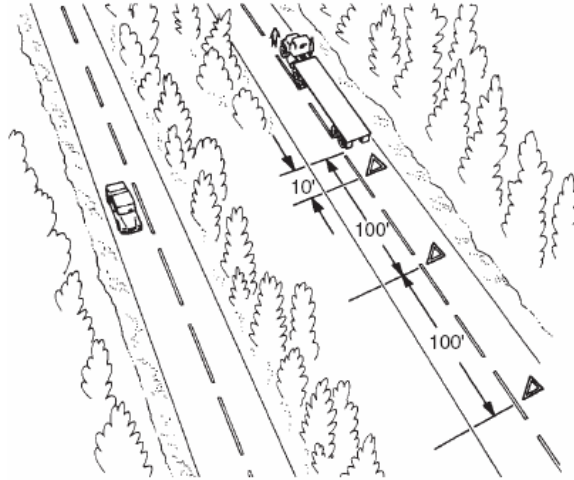

Warning Device Placement: One Way or Divided Highway

FIRST AID

First aid is the immediate and temporary care given the victim of an accident or sudden illness, until the service of a physician can be engaged. First aid is not intended to replace the professional medical person. Even in minor cases, the patient should see a physician as soon as possible.

First aid rendered correctly controls loss of blood, may restore natural breathing, assists circulation, prevents or lessens shock, protects wounds and burns from infection, immobilizes fractures and dislocations, lessens pain, and conserves the patient's strength, so that when medical aid is provided, recovery is enhanced.

The principle objectives of first aid are:

1. Checking conditions known to be endangering life.
2. Protecting injuries from infection and complications.
3. Preventing further injuries.
4. Making the patient as comfortable as possible, to conserve strength.
5. Transporting the patient to medical assistance, when required, in such a manner as not to complicate the injury or subject the patient to unnecessary discomfort.

Some students may require special care for certain physical needs. It is the school administration's responsibility to inform you of those needs. Your

supervisor should supply this information to you and explain how to meet those needs.

Since the students are under your direct care while they are on the school vehicle, part of your own preparation for emergencies and accidents is getting first aid training. First aid training must be valid at all times. When the driver's first aid card expires, they must be removed from service until it is renewed.

"GOOD SAMARITAN" LAW

Good Samaritan laws were enacted in the United States to give legal protection to people who willingly provide emergency care to ill or injured persons without accepting anything in return. They require that the "Good Samaritan" use common sense and a reasonable level of skill, not to exceed the scope of the individual's training in emergency situations.

In Oregon the protection may be found in ORS 30.800. See Appendix B for the scope of the Statute.

EVACUATION DECISION

After an accident or breakdown, you, the driver, must make a decision whether to evacuate the vehicle.

Do not evacuate if the emergency does not endanger the occupants or if outside conditions such as extreme cold, deep snow, or lightning present greater hazards than remaining in the vehicle.

Do evacuate if the vehicle is on fire or in danger of fire, or if it is in an unsafe position in terms of the vehicle being concealed from other motorists because of hills or curves.

Stop and evacuate immediately if the engine or any portion of the vehicle is on fire. Evacuate if the vehicle is near an existing fire and you are unable to move the vehicle away or if presence of gasoline or other combustible material creates a danger of fire.

If the vehicle is stopped in any hazardous position, it should be evacuated. Hazardous positions include:

- On or near railroad tracks.
- In an intersection or where lack of visibility might cause a collision; for instance, near a sharp curve, below the crest of a hill, or in a dip in the road.

- A place from which the position could change, such as at the edge of a steep bank, near the top of a steep grade, or near the edge of a body of water.

EMERGENCY EXITS

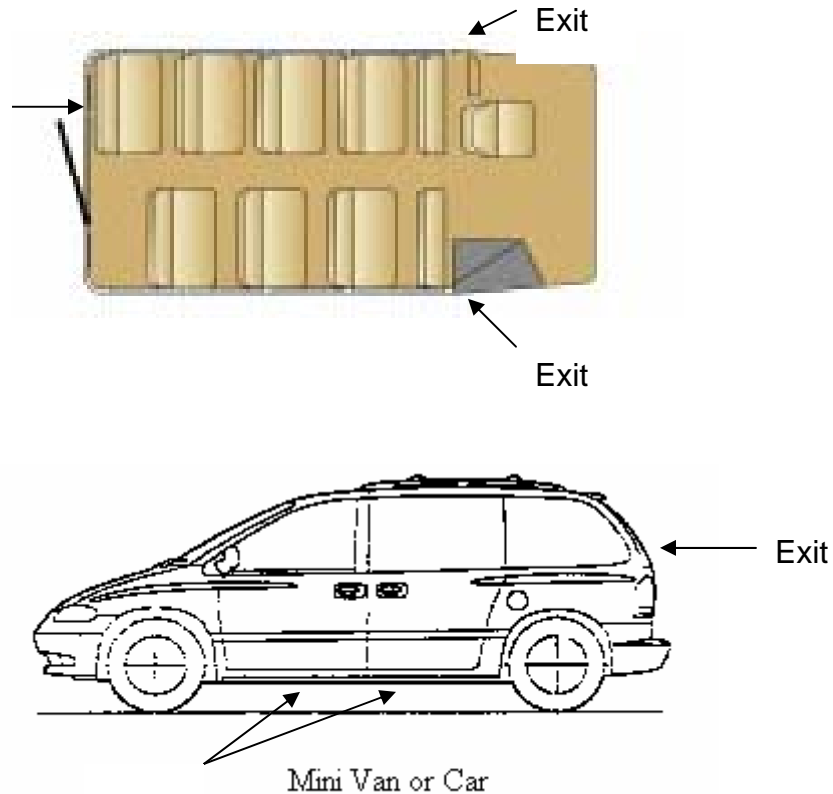

EVACUATION PROCEDURES

You have decided to evacuate. You will need to use your initiative to meet the demands of the situation.

- Stop the vehicle, of course. If it is at all possible, stop it away from traffic and other hazards.
- Set the emergency brake, put the vehicle in park, turn off the engine, and remove the key. Unfasten your seat belt.
- Take several deep breaths to get control before you think or act. Now you will come some heavy decision-making!

- D. Decide which exits will be best to use for evacuation. (Use the front door only, unless another way would be safer considering the vehicle's position, immediate hazards, and the time you can afford.)
- E. Decide where the students are to assemble outside the vehicle.
1. At least 100 feet off the road in the direction of oncoming traffic.
 2. If fire is present, lead the students upwind of the vehicle.
 3. Lead the students as far away from railroad tracks as possible and in the direction of any oncoming train.
 4. Lead students upwind of the vehicle at least 300 feet if there is a risk from spilled hazardous material.
 5. Avoid areas subject to flash flooding.
- F. Take time for several more slow, deep breaths to get control before you speak. When you do speak, keep your voice calm – not loud or high-pitched.
- G. Face the students and tell them that they are going to evacuate, where to meet outside, and which exits to use. Be sure to name a specific place to meet. Mention the exit last because the students will be eager to leave and the word "DOOR" would tend to set them in motion.
- H. Gather whatever emergency equipment you will need before you leave the vehicle.
- I. There are several things you can do to help assure a safe evacuation. These are:
1. Order the students to remain in their seats until it is their turn to leave.
 2. Caution tall students to duck as they go through emergency exits.
 3. Should a rear door evacuation be necessary, you should tell students wearing skirts to gather them around their knees before exiting so that skirts will not get caught and cause falls. Students should sit and scoot out.
 4. Let each student, as far as possible, decide how much assistance they will need to exit out the emergency door. Students should be taught never to pull anyone out, but to offer a hand, palm up, and let the one coming through the exit grasp it.
- J. When everyone is out, check the students at their assembly point to assure their safety and to give them reassurance. Tell them you appreciate their cooperation, if they have done well, and ask them to continue helping you.

ACCIDENT REPORTING PROCEDURES

Oregon Department of Education has defined an accident as an occurrence that results in any of the following: (OAR 581-053-0015(7)(x))

- (a) An injury requiring medical or dental treatment.
- (b) Any damage to property other than the pupil-transporting vehicle.
- (c) Damage to the pupil-transporting vehicle in excess of seven hundred and fifty dollars (\$750.00).

1. In the event the activity vehicle is involved in an accident, the following procedures should be followed:

- a. Drivers will exercise best judgment to ensure the School or Transportation Department is notified as soon as possible. The activity vehicle driver, student, or passerby may make notification.
- b. Driver or students initiate evacuation procedures, if required, and designated person notifies the Transportation Department.
- c. Notify the appropriate police or sheriff department if not done already.
- d. The accident will be reported to one of the following numbers:

Day Time: _____

After Hours: _____

2. The following information should be relayed to the designated School official or the Transportation Department by the driver, students (send two or more), or passerby. See Activity Vehicle: Breakdown -Emergency Report Form

- a. Location of accident.
- b. Vehicle number and activity group.
- c. Any injuries or suspected injuries.
- d. Extent of vehicle damage and other vehicular involvement.
- e. Disposition of the vehicle – blocking traffic, vehicle on side, in culvert, etc.
- f. Any fuel leakage.

3. The School or Transportation Department will initiate the following action:

- a. Notify the appropriate police or sheriff department, if required.
 - b. Request ambulance and/or fire department services, if required.
 - c. Advise principal(s) of school(s) affected.
 - d. Notify parents as per policy.
 - e. Dispatch replacement vehicle and driver to the scene of the accident, if required.
 - f. Notify others as per district policy.
4. The following reports will be completed by the driver and submitted to the school official for review and distribution within time to meet reporting requirements. These forms may be obtained from the school office or the Transportation Department.
- a. School Bus Accident Report, Oregon Department of Education, Pupil Transportation Services, Form 581-2250 (OAR 581-053-0015(7)(x)). Due within 72 hours.
 - b. Traffic Accident and Insurance Report, Oregon Department of Transportation, Form 735-32. Due within 72 hours.
 - c. Student Injury Report and other reports as required by the school or Transportation Department.

MISCELLANEOUS REGULATIONS

DRIVING HOURS

An activity vehicle driver may only drive for 3 hours without taking a 15 minute brake from driving duties. The maximum driving time may not exceed 10 hours in a 15 hour period. Except in emergency situations, the hours may not extend. Examples of an emergency might be mechanical breakdown, adverse road conditions, or accident.

When planning a trip, keep in mind it will take longer in an activity vehicle than in your personal automobile. The activity vehicle in most cases will travel at a slower speed (55 maximum on the Interstate) than your personal automobile and stopping for a driving brake may not be something you normally do.

SPEED LAWS

An activity vehicle must obey all speed limits or laws. In Oregon, the maximum speed for a school activity vehicle is 55 miles per hour. (ORS 811.111) Violation of the speed limit will not reflect well for the school and can create an unsafe situation. A well prepared driver will depart for the trip with the proper amount of time to get to the activity without violating the speed limit. Late arrival

will not improve performance of the students in their activity, and neither will a trip that is unsafe, Should a crash occur arrival will be even latter.

SEAT BELTS AND SAFETY SYSTEMS

Seat belts or restraints must be used by occupants when the vehicle is in operation. There are no exemptions for activity vehicles. Failure to do so could result in a citation for each person who is not wearing the seat belt or safety harness correctly. (ORS 811.210)

CELL PHONES

An activity driver should not use a cellular telephone while operating the vehicle except under the following conditions:

1. For the purpose of communication with any of the following regarding an emergency situation:
An emergency situation involving a 911 operator, hospital, ambulance, fire department, police, or physician.
2. To call for assistance, if there is a mechanical breakdown or mechanical problem impairing the operation of the vehicle.
3. When the vehicle is parked.

CARGO

Ideally, everything except the passengers would travel in under-body storage areas and baggage compartments; few activity vehicles have this luxury. Therefore, the safest way to carry clothing, packs, and special athletic or musical equipment is to send it in a separate vehicle. Care should be used when loading and storing cargo if it is transported in the same vehicle as passengers.

The aisle and emergency exits (including exit windows) must be kept clear. Heavy items should go in first, to be placed as low as possible, and nothing should extend higher than a seat back. (OAR 581-053-0550(6))

All items likely to cause injury to a passenger in the event of an accident must be secured.

FUELING

Fueling the vehicle is best done when the vehicle is not needed for transporting passengers. Fuel before the time to pick up the passengers or at the end of the trip when the passengers have been returned to the school or their final destination. This may not always be possible, such as when a trip will exceed the distance the vehicle may travel without fueling. In these situations, all passengers (including other adults traveling with the group) must exit the vehicle

while it is being fueled. The engine in all cases must be turned off. (OAR 581-053-0550(6))

**APPENDIX A
OREGON ADMINISTRATIVE RULES**

OAR 581-053-0006(8) Driving and Criminal Records:

(a) The Oregon Department of Education shall review the driving record of each applicant before a permit or certificate is issued or renewed. Applicants who have held a driver's license in a state other than Oregon anytime during the preceding three-year period shall furnish, upon request, a copy of the driving record from such state or states to the Oregon Department of Education at time of application;

(b) The Oregon Department of Education shall review the criminal record of a driver upon original application for a permit, certificate or renewal;

(c) An applicant shall be refused a school bus driver's certificate or a current certificate shall be suspended or revoked if the applicant or driver:

(A) Has ever been convicted of crime listed in ORS 342.143;

(B) Has ever been convicted of a crime involving violence, threat of violence, or theft. This shall not apply if applicant or driver has been free from custody, probation and parole for the preceding three-year period from date of application;

(C) Has ever been convicted of a crime involving activity in drugs or alcoholic beverages. This shall not apply if the applicant or driver has been free from custody, probation, and parole for the preceding three-year period from date of application;

(D) Has had a driver's license suspended by the Division of Motor Vehicles of any state, within the preceding three year period, for a cause involving the unsafe operation of a motor vehicle or because of driving record;

(E) Has been convicted within the preceding three-year period of:

(i) Hit-and-run driving;

(ii) Driving under the influence of intoxicants as defined in ORS 813.010;

(iii) Reckless driving as defined in ORS 811.140;

(iv) Fleeing or attempting to elude a police officer while driving a motor vehicle;

(v) Failure to perform the legal duties of a driver involved in an accident or collision which results in injury or death of any person.

(F) Has had driving privileges revoked or suspended as a habitual offender under ORS 809.600. This shall not apply if applicant or driver has had driving privileges restored under ORS 809.660 for the preceding three years;

(G) Has a driving record for the preceding three-year period that has an accumulation of 31 or more points based upon the following point system:

(i) Each chargeable accident and each conviction for a moving violation of traffic laws shall have a value of 10 points. A chargeable accident is one in which the driver is answerable as the primary cause of, or chargeable with the result of an accident;

(ii) One point shall be subtracted from the total number of points for each full month, since the last chargeable accident or conviction, to the time of driving record check; however, all subtracted points will be reinstated if any additional moving violation convictions or chargeable accidents occur within the three-year calculation period;

OAR 581-53-015(7) Accident reporting requirement

(x) Make written reports of accidents involving the pupil-transporting vehicle to the Oregon Department of Education. Reports shall be mailed within 72 hours of the accident. Drivers shall use forms provided by, or approved by, the Oregon Department of Education. An accident is defined as an occurrence that results in any of the following:

(A) An injury requiring medical or dental treatment;

(B) Any damage to property other than the pupil-transporting vehicle;

(C) Damage to the pupil-transporting vehicle in excess of seven hundred and fifty dollars.

(y) Make other reports as required by the local district, the Oregon Department of Education and the Motor Vehicles Division:

OAR 581-053-0545 Type 10 Pupil Transporting Vehicle standards and rules for operation

(1) Definitions of terms used in this rule:

(a) "Type 10 vehicle": Type 10 vehicles shall have a capacity of not more than ten persons, shall have a gross vehicle weight rating of not more than 10,000 pounds and are used to transport students to and from school or authorized school activities. These vehicles shall not be marked with the words "School Bus" and shall be determined by class in accordance with provisions of ORS 820.150 and are not exempted by ORS 801.455 or 801.460;

(b) "Pupil transporting vehicle": A pupil transporting vehicle is defined by OAR 581-053-0002(1)(c);

(c) "Authorized official": An authorized official means a person designated by the local employer.

(2) Construction and equipment:

(a) Vehicle construction shall be according to manufacturers' standard for all vehicles having a capacity of ten or fewer persons including the driver. Capacity shall be based on each vehicle's manufacturer-designated seating capacity;

(b) Equipment shall be the manufacturers' standard plus:

(A) 24-unit first aid kit, in accordance with requirements set forth in OAR 581-053-0517(13)(e). Existing Type 10 vehicles in a fleet prior to June 1, 1986, may be equipped with the previously approved 16-unit first aid kit;

(B) U.L. approved five pound-2A.10BC fire extinguisher (plastic head not permissible), in accordance with OAR 581-053-0517(13)(d). Existing Type 10 vehicles in a fleet prior to June 1, 1986, may be equipped with the previously approved five pound-10 BC fire extinguisher;

(C) D.O.T. approved triangular disabled vehicle road reflectors, in accordance with OAR 581-053-0517(13)(b);

(D) A seat belt approved by the Oregon Division of Motor Vehicles, provided for each seating position;

(E) Any alterations or equipment necessary to accommodate special needs of handicapped children, in accordance with the applicable standards in OAR 581-053-0527.

(3) Annual vehicle inspection: An annual inspection shall be completed for each vehicle (all applicable items on Form 581-2255), and certification of inspection and repair (Form 581-2256) shall be returned to ODE in accordance with OAR 581-053-0008(1) and (2).

(4) Operating rules: Operating rules for Type 10 pupil transporting vehicles when used to transport students for authorized school activities and/or to and from school on an unscheduled, irregular basis:

(a) District requirements -- Districts shall adopt and implement policies and procedures to assure adequate training for all Type 10 vehicle drivers, including:

(A) Emergency procedures and evacuation training;

(B) Vehicle pretrip inspection training; and

(C) Others as considered necessary.

(b) District shall immediately notify the Department of Education if they have reasons to believe any change in the driver(s)' criminal or driving records has occurred which could effect the person(s) ability to meet the licensing provisions listed in OAR 581-053-0006(8);

(c) Driver requirements -- Each driver shall:

(A) Be at least 18 years of age as required by ORS 820.190;

(B) Possess a valid driver license or Oregon commercial driver license. The Oregon Department of Education may approve an out-of-state operator's license if consistent in provision with the required Oregon license;

(C) Possess or obtain within 120 days of original vehicle use request, a valid first aid card; i.e., an American Red Cross First Aid program requirements or an equivalent course that is consistent with US Department of Labor Occupational Safety & Health Administration Guidelines for First Aid

Programs, Directive Number CPL 2-2.53 effective January 7, 1991. A valid first aid card must then be maintained at all times;

(D) Pass a driving and criminal records check by meeting requirements specified in OAR 581-053-0006(8);

(E) Receive emergency procedure and evacuation training, vehicle pretrip inspection training and all other training as determined necessary locally. Pretrip inspections may include:

(i) Windshield and wipers;

(ii) All outside lights;

(iii) Service door, emergency door and buzzer;

(iv) Tires and wheel lug nuts;

(v) Battery, belts, oil and coolant level;

(vi) Horns;

(vii) Brakes;

(viii) Steering;

(ix) Exhaust system;

(x) Emergency equipment; and

(xi) See that lights, windshield and mirrors are clean.

(F) Receive specialized training designed for special education transportation prior to transporting students with disabilities;

(G) Be judged by an authorized official as having the ability to operate the Type 10 vehicle safely and to perform related duties. Examples of related duties include, but are not limited to, handling stressful situations such as mechanical breakdowns, traffic accidents, and unruly students;

(H) Be placed on an approved driver list maintained at the Oregon department of Education. An authorized official shall provide a signed certification that the driver has completed or shall complete all requirements prior to transporting passengers, except for the first aid training provision which must be completed within 120 days as required by paragraph (5)(b)(C) of this rule. Approval expires on July 1 annually upon failure to comply with any rule requirements or termination of employment from district submitting approval list;

(I) Complete accident reports as required for school bus drivers by OAR 581-053-0015(7)(y);

(J) Report to his/her employer(s) within 15 days, any conviction for driving or criminal offenses specified in OAR 581-053-0006(8) or any involvement in an accident as defined in OAR 581-053-0006(8)(c)(G)(i);

- (K) Not operate a vehicle with more passengers than the manufacturer's rated capacity;
 - (L) Instruct passengers to use seat belts at all times the vehicle is in motion;
 - (M) Maintain order in the vehicle at all times. The inside of the vehicle shall be kept clean;
 - (N) See that all doors on the vehicle are kept closed while the vehicle is in motion;
 - (O) Not permit anyone else to operate the vehicle except with the permission of authorized officials;
 - (P) Make certain that all aisles and passageways are kept clear;
 - (Q) Make sure all rear doors (emergency exits) are unlocked during vehicle operation;
 - (R) Not use tobacco on the vehicle and shall not permit passengers to use tobacco on the vehicle;
 - (S) Not be under the influence of any alcoholic beverage or any drug likely to affect the person's ability to operate a vehicle safely while on duty;
 - (T) Not consume any alcoholic beverage regardless of its alcoholic content or any drug likely to affect a person's ability to operate a vehicle safely while on duty or within eight hours before going on duty to operate or to have physical control of a pupil-transporting vehicle;
 - (U) Not permit signs of any kind to be attached to the vehicle except those specifically permitted by law or regulation;
 - (V) Not permit animals in the vehicle; however, guide dogs are allowed when accompanying a blind or deaf person as are other assistance animals and guide/assistance animals in training that comply with OAR 581-053-0015(7)(j);
 - (W) Not permit firearms, other weapons, or potentially hazardous materials in the vehicle;
 - (X) Secure any article in the passenger compartment likely to cause injury to a passenger in the event of an accident;
 - (Y) Not fill the fuel tank while passengers are in the vehicle or while the motor is running;
 - (Z) Not leave the vehicle when passengers are aboard until the motor is shut off, the brakes set, a manual transmission put in gear and the key removed from the ignition;
 - (AA) Report as soon as possible to the proper official any deficiency or malfunction of any equipment or component of the vehicle;
 - (BB) Not alter routes unless approved by school authorities;
 - (CC) Shall use all securement straps and attachments for students with adaptive/assistive devices in a manner consistent with their design.
- (d) Driving hour limitations:

(A) Except as provided by paragraph (5)(c)(B) of this rule, a driver shall not drive any pupil transporting vehicle more than a total of ten hours during any consecutive 15-hour period. At the end of ten hours of driving or a 15-hour period, whichever occurs first, the driver shall not again drive any pupil transporting vehicle until at least eight hours have elapsed;

(B) The driver of any pupil transporting vehicle, after driving a regular morning route transporting pupils from home to school, may again operate any pupil transporting vehicle, but not more than eight hours in a consecutive ten hour period or until 12 midnight, whichever occurs first, provided the driver has at least four hours free from actual operation of a pupil transporting vehicle following the end of the morning route. To qualify under this provision, the driver shall have been free from pupil transporting vehicle driving duties for at least eight consecutive hours prior to the regular morning route;

(C) A driver shall not drive more than three hours continuously without taking at least a 15-minute break from driving duties;

(D) Emergency extension of driving hours: In the event of an unforeseen emergency, e.g., mechanical breakdown, accident or adverse road conditions, a driver may complete the trip without being in violation of the provisions of this rule if such trip could have reasonably been completed as originally scheduled without violation of this rule.

(5) Operating rules for Type 10 pupil transporting vehicles when used for regularly scheduled student transportation to and from school:

(a) District requirements are the same as those listed in subsection (5)(a) of this rule when used to transport students for authorized activities and/or to and from school on an unscheduled, irregular basis;

(b) Driver requirements are the same as those listed in subsection (5)(b) of this rule, when used to transport students for authorized activities and/or to and from school on an unscheduled, irregular basis, plus the driver shall:

(A) Demonstrate necessary vehicle operational skills (in a vehicle to be used) to the authorized official through a behind-the-wheel test; and

(B) Demonstrate to an authorized official, a knowledge of laws and regulations applicable to the vehicle being used.

(c) Driver rules are the same as those listed in subsection (5)(b) of this rule, when used to transport students for authorized activities and/or to and from school on an unscheduled, irregular basis plus the following;

(d) Drivers shall inspect the following prior to each trip, unless the inspection is performed by other designated employees:

(A) Windshield and wipers;

(B) All outside lights;

(C) Service door, emergency door and buzzer;

- (D) Tires and wheel lug nuts;
- (E) Battery, belts, oil, and coolant level;
- (F) Horns;
- (G) Brakes;
- (H) Steering;
- (I) Exhaust system;
- (J) Emergency equipment; and
- (K) See that lights, windshield and mirrors are clean.

(e) Driving hour limitations are the same as those listed in subsection (5)(c) of this rule, when used to transport students for authorized activities and/or to and from school on an unscheduled, irregular basis.

(6) Occasional/emergency use provision -- A person who does not currently meet the driver requirements for a Type 10 pupil transporting vehicle may be used on an occasional/emergency basis if such driver:

- (a) Is judged competent by the local authorized official;
- (b) Possesses a valid driver license or Oregon commercial driver license;
- (c) Does not operate vehicles under this provision more than three times in any given fiscal year (July 1 to June 30); and
- (d) Is not transporting students to and from school on regularly scheduled routes.

OAR 581-053-0550 Type 20 Pupil Transporting Vehicle Standards

(1) Definitions of terms used in this rule:

(a) "Type 20 vehicle": Type 20 vehicles shall have a capacity of not more than 20 passengers, shall have a gross vehicle weight rating of not more than 14,500 pounds, and are used to transport students to and from authorized school activities. These vehicles shall not be marked with the words "school bus" and shall be determined by class in accordance with provisions of ORS 820.150 and are not exempted by ORS 801.455;

(b) "Pupil transporting vehicle": A pupil transporting vehicle is defined by OAR 581-053-0002(1)(b);

(2) Vehicles shall meet all minimum construction and equipment standards of a Type A-1 school bus except for the following:

(a) Identification required by OAR 581-053-0517(16)(a) and (b). The words "School Bus" may not appear on a vehicle, which does not comply with all school bus requirements provided for in ORS 820.100 and 820.110. Activity vehicles may have fleet identification;

(b) Color required by OAR 581-053-0517(5). The vehicle may be painted school bus yellow if desired;

(c) Lights required by OAR 581-053-0517(21)(k). Only vehicles described in ORS 816.350(8) may be equipped with and display bus safety lights;

(d) Public address systems required by OAR 581-053-0517(30)(c).

(3) An annual inspection shall be completed for each vehicle (all applicable items on Form 581-2255), and certification of inspection and repair (Form 581-2256) shall be returned to the Oregon Department of Education in accordance with OAR 581-053-0008(1) and (2).

(4) District shall immediately notify the Department of Education if they have reason to believe any change in the driver(s)' criminal or driving record has occurred which could effect the person(s)' ability to meet the licensing provisions listed in OAR 581-053-0006(8).

(5) No person shall transport pupils in a Type 20, unless such person has completed all requirements for a Type 20 certificate and meets the standards established by the Department for Type 20 activity drivers.

(6) Type 20 Original Certificate. The Oregon Department of Education shall issue a Type 20 certificate to qualified individuals who meet the following requirements:

(a) Be at least 18 years of age as required by ORS 820.190;

(b) Possess the required license as follows:

(A) A valid driver's license for vehicles with a passenger capacity of 14 or less, or:

(B) An Oregon commercial driver license with passenger endorsement for vehicles with a passenger capacity of 15 or more, provided the driver has

(i) a valid medical card, as defined in 735-074-0280

(ii) been enrolled in a drug and alcohol screening requirements by the Federal Highway Administration for Commercial Drivers.

(C) The Oregon Department of Education may approve an out-of-state operator's license if it is consistent in provision with the required Oregon license;

(c) Has completed a minimum of two hours of approved behind-the-wheel training within one year of application by a trainer certified by the Oregon Department of Education. Hours of behind-the-wheel training shall be those hours spent by the trainee with a certified trainer or an assistant approved by the Oregon Department of Education in actual operation of the vehicle or vehicles the applicant will be expected to drive. Training shall include

(A) Complete training for proper vehicle pretrip inspection;

(B) Demonstrate knowledge of laws and regulations applicable to the vehicle being used

(C) Complete emergency procedure and evacuation training;

(d) Demonstrate necessary vehicle operational skills (in the vehicle to be used) to an authorized official through a behind-the-wheel test, administered by a trainer certified by the Oregon Department of Education (e) Pass a driving and criminal records check by meeting current requirements of issuance for a school bus driver's license, as specified in OAR 581-053-0006(8).

(f) Possess or obtain within 120 days of original use request a valid first aid card; i.e., A valid first aid card must then be maintained at all times;

(g) Complete accident reports as required of school bus drivers by OAR 581-053-0015(7)(y);

(h) Report to he/her employer(s) within 15 days, any conviction for driving or criminal offenses specified in OAR 581-053-0006(8) or any involvement in an accident as defined in OAR 581-053-0006(8)(c)(G)(i);

(i) Drivers who are transporting special education students should receive specialized training designed for this purpose;

(j) Not operate a vehicle with more passengers than the manufacturers designed or equipped capacity;

(k) Instruct passengers to use seat belts at all times the vehicle is in motion;

(l) Maintain order in the vehicle at all times. The inside of the vehicle shall be kept clean;

(m) See that all doors on the vehicle are kept closed while the vehicle is in motion;

(n) Not permit anyone else to operate the vehicle except with the permission of authorized officials;

- (o) Make certain that all aisles and passageways are kept clear;
- (p) Make sure all rear doors (emergency exits) are unlocked during vehicle operation;
- (q) Not use tobacco in the vehicle or the vicinity and shall not permit passengers to use tobacco on the vehicle;
- (r) Not be under the influence of any alcoholic beverage or any drug likely to affect the person's ability to operate a vehicle safely while on duty;
- (s) Not consume any alcoholic beverage regardless of its alcoholic content or any drug likely to affect a person's ability to operate a vehicle safely while on duty or within eight hours before going on duty to operate or to have physical control of a pupil-transporting vehicle;
- (t) Not permit signs of any kind to be attached to the vehicle except those specifically permitted by law or regulation;
- (u) Not permit animals in the vehicle; however, guide dogs are allowed and assistance animals as well as guide/assistance animals in training that comply with OAR 581-053-0015(7)(j);
- (v) Not permit firearms, other weapons, or potentially hazardous materials to be carried in the vehicle;
- (w) Secure any article in the passenger compartment likely to cause injury to a passenger in the event of an accident;
- (x) Not fill the fuel tank while passengers are in the vehicle or while the motor is running;
- (y) Not leave the vehicle when passengers are aboard until the motor is shut off, the brakes set, a manual transmission put in gear and the key removed from the ignition;
- (z) Report as soon as possible to the proper official any deficiency or malfunction or any equipment or component of the vehicle;
- (aa) Not alter routes unless approved by school authorities;
- (bb) Shall inspect the following prior to each trip, unless the inspection is performed by other designated employees:
 - (A) Windshield and wipers;
 - (B) All outside lights;
 - (C) Service door, emergency door and buzzer;
 - (D) Tires and wheel lug nuts;
 - (E) Battery, belts, oil and coolant level;
 - (F) Horns;

(G) Brakes;

(H) Steering;

(I) Exhaust system;

(J) Emergency equipment; and

(K) See that lights, windshield and mirrors are clean.

(cc) Shall use all securement straps and attachments for students with adaptive/assistive devices in a manner consistent with their design.

(dd) Shall not tow a trailer with a gross vehicle weight rating of more than 3,000 lbs or longer than the towing vehicle.

(7) Type 20 Certificate Renewal. The Oregon Department of Education shall issue a Type 20 certificate to qualified individuals who meet the following requirements:

(a) Possesses or has possessed within the last 12 month period a valid Type 20 certificate.

(b) Possess the required license as follows:

(A) A valid driver's license for vehicles with a passenger capacity of 14 or less, or:

(B) An Oregon commercial driver license with passenger endorsement for vehicles with a passenger capacity of 15 or more, provided the driver has

(i) a valid medical card, as defined in 735-074-0280

(ii) been enrolled in a drug and alcohol screening requirements by the Federal Highway Administration for Commercial Drivers.

(C) The Oregon Department of Education may approve an out-of-state operator's license if it is consistent in provision with the required Oregon license;

(8) Expiration:

(a) Type 20 certificates shall be valid for two years. Certificates will not be valid if:

(A) First Aid card has expired or

(B) Medical Card has expired if applicable

(9) Driving hour limitations:

(a) Except as provided by subsection (5)(b) of this rule a driver shall not drive any pupil transporting vehicle more than a total of ten hours during any consecutive 15-hour period. At the end of ten hours of driving or a fifteen hour period, whichever occurs first, the driver shall not again drive any pupil transporting vehicle until at least eight hours have elapsed;

(b) The driver of any pupil transporting vehicle, after driving a regular morning route transporting pupils from home to school, may again operate any pupil transporting vehicle, but not more than eight hours in a consecutive ten hour period or until 12 midnight, whichever occurs first, provided the driver has at least four hours free from actual operation of a pupil transporting vehicle following the end of the morning route. To qualify under this provision, the driver shall have been free from pupil transporting vehicle driving duties for at least eight consecutive hours prior to the regular morning route;

(c) A driver shall not drive more than three hours continuously without taking at least a 15-minute break from driving duties;

(d) Emergency extension of driving hours: In the event of an unforeseen emergency, e.g., mechanical breakdown, accident or adverse road conditions, a driver may complete the trip without being in violation of the provisions of this rule if such trip could have reasonably been completed as originally scheduled without violation of this rule.

(9) Refusals and Suspensions:

(a) The Oregon Department of Education may refuse, suspend or revoke the certificate of a Type 20 driver for noncompliance with certification or license requirements, giving false or incomplete information on application forms, or failure to comply with laws, rules and regulations applicable to Type 20 drivers. Applications with obvious incomplete or inaccurate information will be returned to the employer with no action taken regarding denial or approval;

(10) These rules may be implemented prior to, but are mandatory by January 1, 2006.

**APPENDIX B
OREGON REVISED STATUTES**

ORS 30.800 Liability for emergency medical assistance by medically trained persons.

- (1) As used in this section, "emergency medical assistance" means:
 - (a) Medical or dental care not provided in a place where emergency medical or dental care is regularly available, including but not limited to a hospital, industrial first-aid station or a physician's or dentist's office, given voluntarily and without the expectation of compensation to an injured person who is in need of immediate medical or dental care and under emergency circumstances that suggest that the giving of assistance is the only alternative to death or serious physical after effects; or
 - (b) Medical care provided voluntarily in good faith and without expectation of compensation by a physician licensed by the Board of Medical Examiners for the State of Oregon in the physician's professional capacity as a team physician at a public or private school or college athletic event or as a volunteer physician at other athletic events.
- 2) No person may maintain an action for damages for injury, death or loss that results from acts or omissions of a person while rendering emergency medical assistance unless it is alleged and proved by the complaining party that the person was grossly negligent in rendering the emergency medical assistance.
- (3) The giving of emergency medical assistance by a person does not, of itself, establish the relationship of physician and patient, dentist and patient or nurse and patient between the person giving the assistance and the person receiving the assistance insofar as the relationship carries with it any duty to provide or arrange for further medical care for the injured person after the giving of emergency medical assistance.

ORS 30.805 Liability for emergency medical assistance by government personnel.

- (1) No person may maintain an action for damages for injury, death or loss that results from acts or omissions in rendering emergency medical assistance unless it is alleged and proved by the complaining party that the acts or omissions violate the standards of reasonable care under the circumstances in which the emergency medical assistance was rendered, if the action is against:
 - (a) The staff person of a governmental agency or other entity if the staff person and the agency or entity are authorized within the scope of their official duties or licenses to provide emergency medical care; or
 - (b) A governmental agency or other entity that employs, trains, supervises or sponsors the staff person.
- (2) As used in this section, "emergency medical care" means medical care to an injured or ill person who is in need of immediate medical care:
 - (a) Under emergency circumstances that suggest that the giving of assistance is the only alternative to serious physical aftereffects or death;

(b) In a place where emergency medical care is not regularly available;

(c) In the absence of a personal refusal of such medical care by the injured or ill person or the responsible relative of such person; and

(d) Which may include medical care provided through means of radio or telecommunication by a medically trained person, who practices in a hospital as defined in ORS 442.015 and licensed under ORS 441.015 to 441.087, and who is not at the location of the injured or ill person.

ORS 811.111 Violating a speed limit; penalty.

(1) A person commits the offense of violating a speed limit if the person:

(a) Drives a vehicle on an interstate highway at a speed greater than 65 miles per hour or, if a different speed is posted under ORS 810.180 (3), at a speed greater than the posted speed.

(b) Notwithstanding paragraph (a) of this subsection, drives any of the following vehicles at a speed greater than 55 miles per hour on any highway or, if a different speed is posted under ORS 810.180 (3), at a speed greater than the posted speed:

(A) A motor truck or truck tractor with a gross vehicle weight rating of more than 8,000 pounds.

(B) A school bus.

(C) A school activity vehicle.

ORS 811.210 Failure to use safety belts; penalty.

(1) A person commits the offense of failure to use safety belts if the person:

(a) Operates a motor vehicle on the highways of this state and is not properly secured with a safety belt or safety harness as required by subsection (2) of this section;

(b) Operates a motor vehicle on the highways of this state with a passenger who is under 16 years of age and the passenger is not properly secured with a child safety system, safety belt, or safety harness as required by subsection (2) of this section; or

(c) Is a passenger in a motor vehicle on the highways of this state who is 16 years of age or older and who is not properly secured with a safety belt or safety harness as required by subsection (2) of this section.

(2) To comply with this section:

(a) A person who is under four years of age and weighs 40 pounds or less must be properly secured with a child safety system that meets the minimum standards and specifications established by the Department of Transportation under ORS 815.055 for child safety systems designed for children weighing 40 pounds or less;

(b) Except as provided in subsection (3) of this section, a person who is at least four years of age and under six years of age or weighs between 40 and 60 pounds must be properly secured with a child safety system that elevates the person so that a safety belt or safety harness properly fits the person. "Proper fit" means the lap belt of the safety belt or safety harness is positioned low across the thighs and the shoulder belt is positioned over the collarbone and away from the neck. The child safety system shall meet the minimum standards and specifications established by the Department of Transportation under ORS 815.055 for child safety systems designed for children weighing between 40 and 60 pounds; or

(c) A person who is at least six years of age and weighs 60 pounds or more must be properly secured with a safety belt or safety harness that meets requirements under ORS 815.055.

(3) If the rear seat of a vehicle is not equipped with shoulder belts, the requirements of subsection (2)(b) of this section do not apply provided the person is secured by a lap belt.

(4) The offense described in this section, failure to use safety belts, is a Class D traffic violation.

ORS 811.225 Failure to maintain safety belts in working order; penalty.

(1) The registered owner of a motor vehicle commits the offense of failure of an owner to maintain safety belts in working order if:

(a) The vehicle is equipped with safety belts or safety harnesses that meet the standards established under ORS 815.055; and

(b) The owner fails to maintain the safety belts or safety harnesses in a condition that will enable occupants of all seating positions equipped with safety belts or safety harnesses to use the belts or harnesses.

(2) The offense described in this section, failure of an owner to maintain safety belts in working order, is a Class C traffic violation. [1991 c.2 §5; 1995 c.383 §118; 2003 c.158 §10]

811.460 Failure to follow rail crossing procedures for high-risk vehicles; application; penalty.

(1) A person commits the offense of failure to follow rail crossing procedures for high-risk vehicles if the person takes any vehicle described in this section across any railroad or rail fixed guideway system tracks at grade without doing all of the following:

(a) Stopping the vehicle at a clearly marked stop line or, if there is not a clearly marked stop line, not less than 15 feet nor more than 50 feet from the nearest rail of the railroad or rail fixed guideway system.

(b) While so stopped, listening and looking in both directions along the tracks for approaching trains or rail fixed guideway system vehicles and for signals indicating approaching trains or rail fixed guideway system vehicles.

(c) Proceeding across the tracks after stopping only when such movement can be performed safely in the gear of the motor vehicle that does not require manually changing gears while proceeding.

(d) Proceeding across the tracks without manually changing gears.

(2) This section applies to the following vehicles when moved across railroad or rail fixed guideway system tracks:

(a) A school bus.

(b) A school activity vehicle with a loaded weight of 10,000 pounds or more.

ORS 811.455 Failure to stop for railroad signal; penalty.

(1) A person commits the offense of failure to stop for a railroad signal if the person fails to comply with any of the following requirements:

(a) A person who is driving a vehicle must stop the vehicle at a clearly marked stop line on the near side of a railroad crossing or, if there is no clearly marked stop line, not less than 15 feet nor more than 50 feet from the nearest rail of the crossing under any of the following circumstances:

(A) When a clearly visible electric or mechanical signal is given by a device that warns of the immediate approach of a railroad train.

(B) Upon the lowering of a crossing gate.

(C) When a signal given by a flagger or police officer indicates the approach or passage of a railroad train.

(D) When an approaching train is clearly visible and because of its nearness to the crossing is an immediate hazard.

(E) When an audible signal is given by an approaching railroad train because its speed or nearness to the crossing is an immediate hazard.

(b) A driver who has stopped for the passing of a train at a railroad grade crossing in accordance with the provisions of this section shall not proceed across the railroad tracks until the driver can do so safely.

(c) A person shall not drive any vehicle through, around or under a crossing gate or barrier at a railroad crossing while the gate or barrier is closed or is being opened or closed.

(2) The offense described in this section, failure to stop for a railroad signal, is a Class B traffic violation

ORS 811.465 Exemptions from high-risk vehicle rail crossing procedures.

This section establishes exemptions from the special crossing procedures established for high-risk vehicles under ORS 811.460. The exemptions are partial or complete as described in the following:

(1) The vehicles are not required to comply with the procedures at a crossing of a street or highway and rail fixed guideway system tracks if:

(a) The rail fixed guideway system vehicles operate within and parallel to the right of way of a street or highway; and

(b) All vehicle movements are controlled by traffic control devices.

(2) The vehicles are not required to comply with the procedures when crossing any railway tracks upon which operation has been abandoned and for which the Department of Transportation has plainly marked that no stop need be made.

(3) The vehicles are not required to comply with the procedures when crossing industry track crossings across which train operations are required by law to be conducted under flag protection.

(4) The vehicles are not required to comply with the procedures when crossing industry track crossings within districts in which the designated speed of vehicles is 20 miles per hour or less.

(5) Vehicles are not required to comply with the procedures when crossing any crossing where an officer directs traffic to proceed or where an operating traffic control signal indicates that other traffic may proceed.

(6) Vehicles are not required to comply with the procedures when crossing any crossing protected by crossing gates. The exemption under this subsection does not apply to:

(a) School buses or school activity vehicles that are required to stop at crossings with crossing gates under ORS 811.460;

(b) Tank vehicles, whether loaded or empty, used to transport hazardous materials;

(c) Vehicles transporting any hazardous material requiring the vehicle to be placarded; or

(d) High-risk vehicles described in ORS 811.460 that are not otherwise described in this subsection, when operating in interstate commerce.

(7) Except when a train or rail fixed guideway system vehicle is approaching, the driver of a commercial bus is not required to stop at crossings where the Department of Transportation has determined and plainly marked that no stop need be made.

ORS 811.530 Failure to post warnings for disabled vehicle; application; penalty.

(1) A person commits the offense of failure to post warnings for a disabled vehicle if the person is the driver, or other person in charge of a vehicle subject to this section, and the person does not cause the placement of such roadside vehicle warning devices as the Department of Transportation may

require under ORS 815.035 when the vehicle is disabled during limited visibility conditions and cannot immediately be removed from the main traveled portion of a highway outside of a business district or residence district.

(2) This section applies only to the following vehicles:

(a) School buses.

(b) School activity vehicles.

(3) Requirements to be equipped with roadside vehicle warning devices are contained in ORS 815.285.

(4) The offense described in this section, failure to post warnings for a disabled vehicle, is a Class B traffic violation.

ORS 820.190 Minor operating school vehicle; penalty.

(1) A person commits the offense of being a minor operating a school vehicle if the person is under 18 years of age and the person drives any of the following while it is in use for the transportation of pupils to or from school or an authorized school activity or function:

(a) A school bus.

(b) A school activity vehicle.

(c) A vehicle owned by a public or governmental agency.

(d) A privately owned vehicle that is operated for compensation that is a vehicle other than a vehicle commonly known and used as a private passenger vehicle and not operated for compensation except in the transportation of students to or from school.

(2) The offense described in this section, minor operating a school vehicle, is a Class B traffic violation. [1983 c.338 §754; 1985 c.420 §19]

APPENDIX C FORMS

Performance Checklist For Type 20 Activity Vehicle Drivers

Driver Name: _____ Department Location: _____

Contact Phone Number: _____ Driver's License No: _____

Do you possess a valid First Aid Card? Yes _____ Expires ____/____/____ If yes please attach a copy No _____ A valid First Aid Card must be obtain within 120 days.

Behind-The-Training (OAR 581-053-0550(6)(c) Sign off when completed:

The trainee must demonstrate the knowledge and/or ability to successfully complete the critical tasks listed in each section before being allowed to progress on through the program. The instructor must initial and date each item when completed and have the trainee initial that the respective training was received.

Review of Laws and Rules

	Instructor	Date	Trainee
Speed limits			
Freeways & Highways			
School zones			
Other			
Railroad crossings			
District policy			
Driving hours			
Loose cargo			

Review of District Policies

	Instructor	Date	Trainee
Cell phone use			
Cleaning post trip			
Fueling			
Location			
During and after use			
Parking (keys)			
Vehicle location			
After use: Securing the vehicle, key return			
Post trip inspection			
Vehicle deficiencies & trip reporting			
Safety concerns			

Special Needs When Applicable

	Instructor	Date	Trainee
Lift use			
Wheel chair securement			
Special equipment			
Medication handling			
Other: list			

Pretrip

	Instructor	Date	Trainee
Emergency equipment			
Triangle reflectors, first aid kit, body fluid kit, belt cutter, fire extinguisher			
Windshield, wipers, windows, and mirrors			
Gauges and instruments			
Steering and horns			
Brake check			
Seats and seatbelts			
Emergency Exits			
Engine compartment			
Tires and wheels			
Fueling area			
Lights & reflectors			
Paint, lettering and damage			

Driving

	Instructor	Date	Trainee
Parking (lot and grade)			
Railroad crossing			
Backing			
Intersections			
Lane use			
Freeway or highway			
Turns and steering			
Speed			
Seatbelt use			
School zone and school grounds			
Urban and rural driving			
Other :list			

Activity Vehicle Seating Chart

ACTIVITY VEHICLE SEATING CHART

Driver Name _____ Date _____

Activity Vehicle # _____ Time _____

School(s) _____

Transported from scene by:

Driver Name _____ Vehicle# _____

Student Names

Seat Numbers

Student Names

		1
		2
		3
		4
		5

1		
2		
3		
4		
5		

